

# S-300

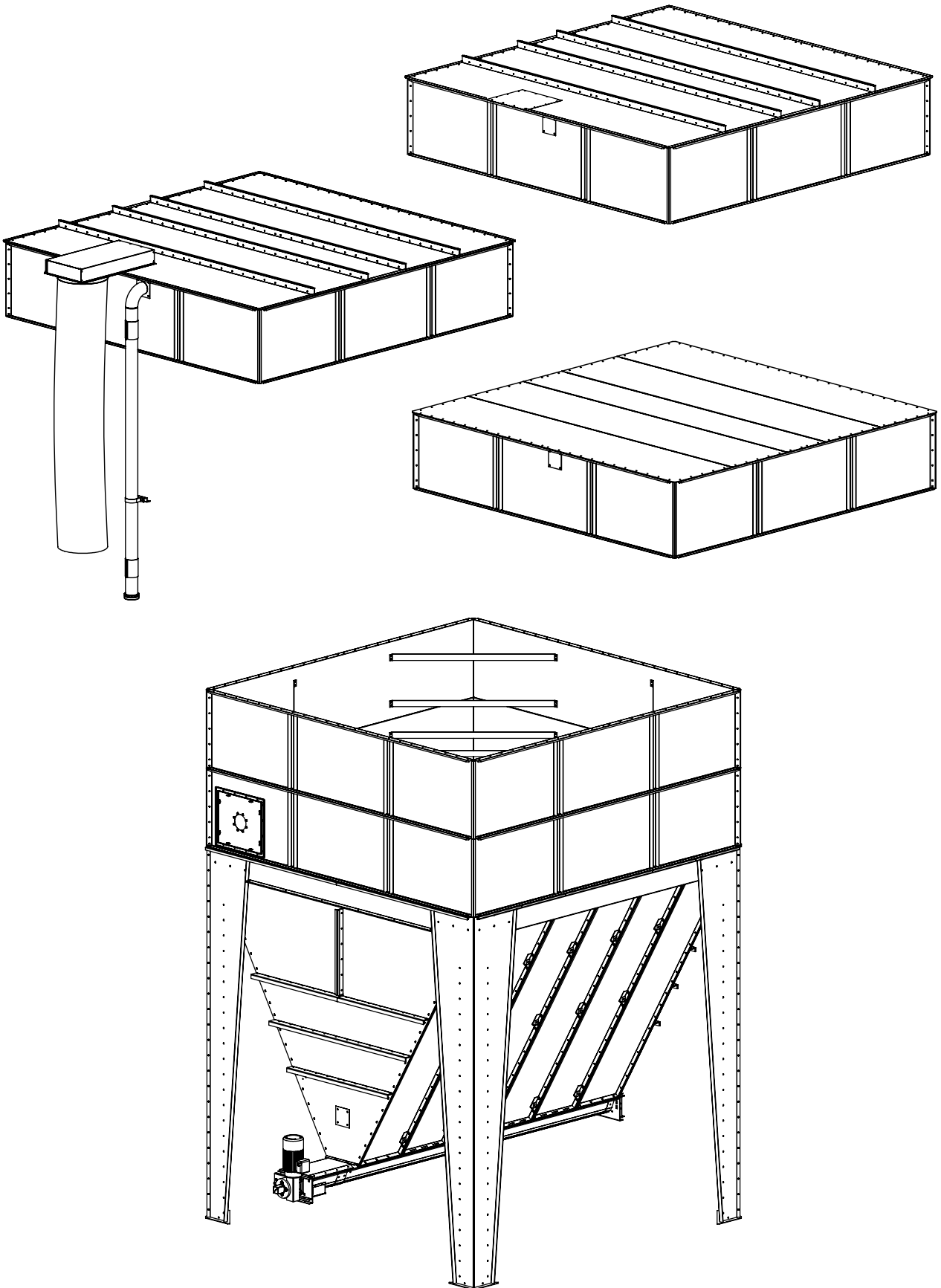

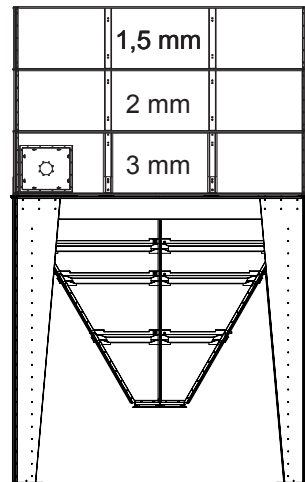

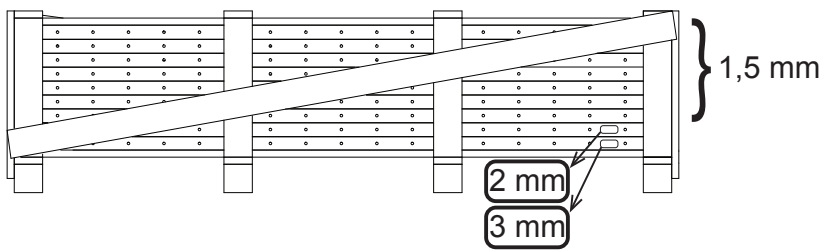

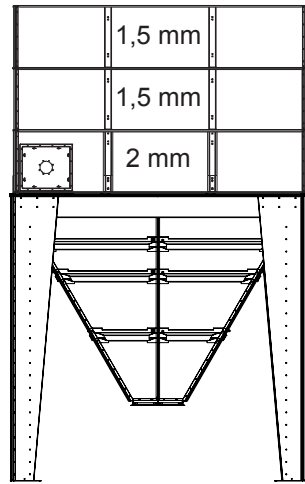
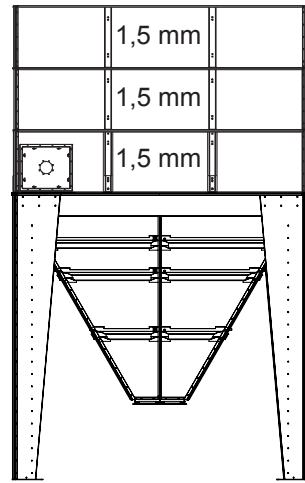
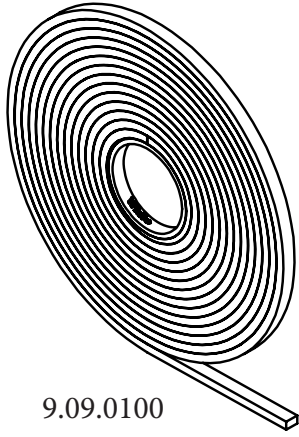



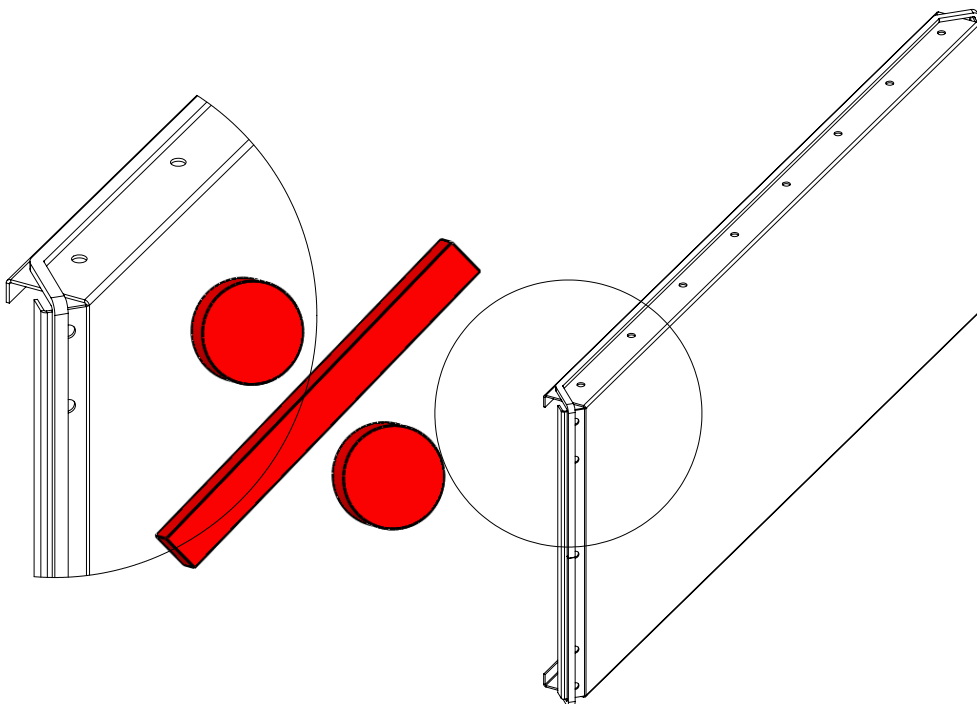
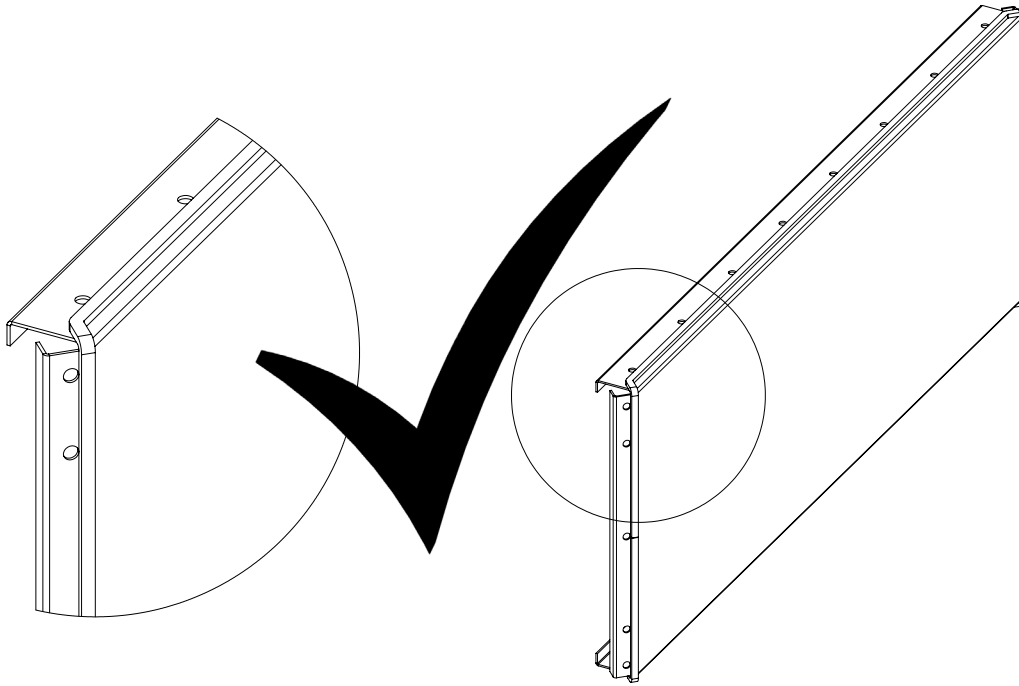



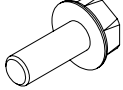
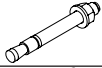

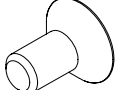
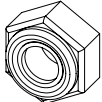
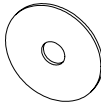
9.09.0100

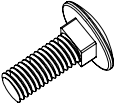
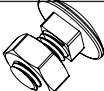
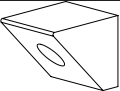
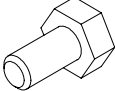

<b>Henvising Citation Zitat</b>	<b>Type Type Typ</b>	<b>Standard Standard Standard</b>	<b>Vare nr. Item no. Artikel-Nr.</b>	
G		M6	DIN 6923 S181	9.01.0301
Q		M8	DIN 6923 S181	9.01.0401
Dd		M10	DIN 6923 S181	9.01.0501
I		M6 x 16	DIN 6921 8.8 FZB	9.01.0313
J		M6 x 25	DIN 6921 8.8 FZB	9.01.0317
S		M8 x 16	DIN 6921 8.8 FZB	9.01.0413
T		M8 x 20	DIN 6921 8.8 FZB	9.01.0415
U		M8 x 25	DIN 6921 8.8 FZB	9.01.0417
V		M8 x 30	DIN 6921 8.8 FZB	9.01.0418
li		M10 x 20	DIN 6921 8.8 FZB	9.01.0515
A		M10 x 25	DIN 6921 8.8 FZB	9.01.0517
lii		M10 x 30	DIN 6921 8.8 FZB	9.01.0518
Jj		M10 x 35	DIN 6921 8.8 FZB	9.01.0524
Nnn		M16 x 150		9.01.0845
O		M6 x 12		9.01.0395
L		M6 x 16	DIN 7991 8.8 FZB	9.01.0370
Aa		M8 x 16	DIN 7991 8.8 FZB	9.01.0470
Qq		M10 x 25	DIN 7991 8.8 FZB	9.01.0572
P		M6	DIN 985 8.8 FZB	9.01.0304
R		M8	DIN 985 8.8 FZB	9.01.0404
Ee		M10	DIN 985 8.8 FZB	9.01.0504
Tt		M12	DIN 985 8.8 FZB	9.01.0604
Vv		M16	DIN 985 8.8 FZB	9.01.0819
Eee		M6		9.01.0303
Gg	M6		9.01.0305	
Yy		M8		9.01.0407
Zz		M8		9.01.0405
Aaa		M8		9.01.0403
Bbb		M8		9.01.0464
Fff		M10		9.01.0510
C		M10		9.01.0503
Ddd		M10		9.01.0505
Jjj		M12		9.01.0607
Ccc		M8		9.01.0406
B		M6 x 12		9.01.0351
Ppp		M8 x 20		9.01.0483
Nn		M10 x 25		9.01.0516
Ss		M10x20+M10		9.01.0514
Bb		60°		4.05.0609
Ff		45°		4.05.0608
Oo		M6 x 35	DIN 933 8.8 FZB	9.01.0319
E		M8 x 35	DIN 933 8.8 FZB	9.01.0419
X		M8 x 40	DIN 933 8.8 FZB	9.01.0420
LI		M10 x 35	DIN 933 8.8 FZB	9.01.0519
Hh		M10	DIN 934 8.8 FZV	9.01.0508
Uu		M12	DIN 934 8.8 FZV	9.01.0600

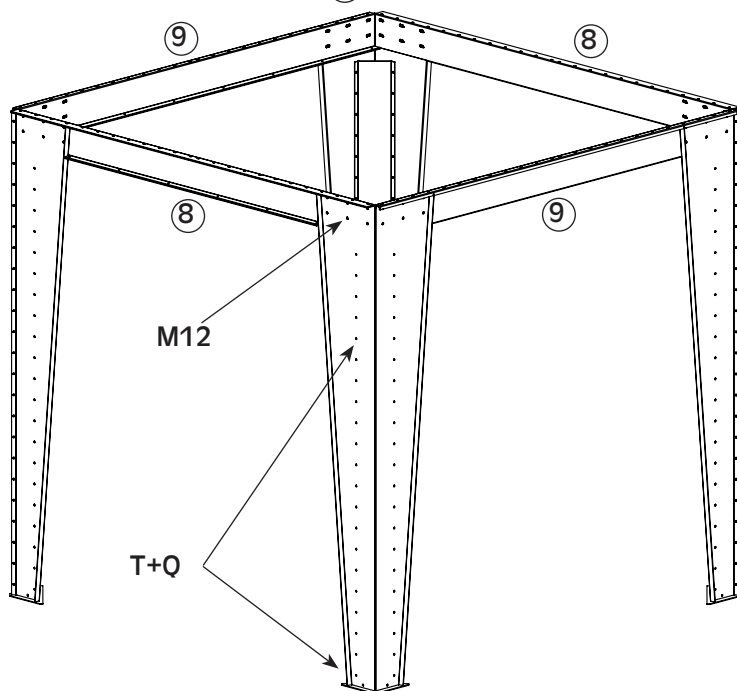
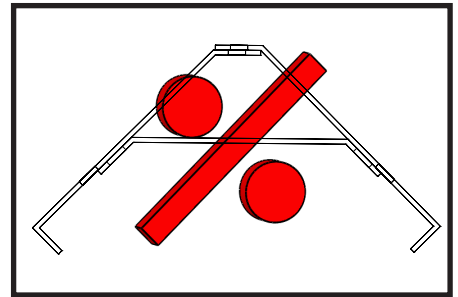
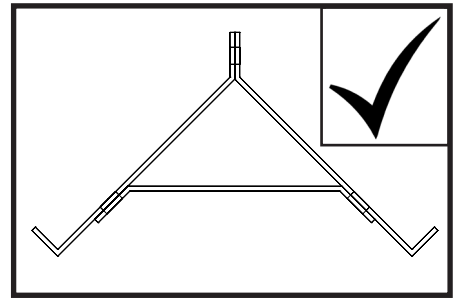
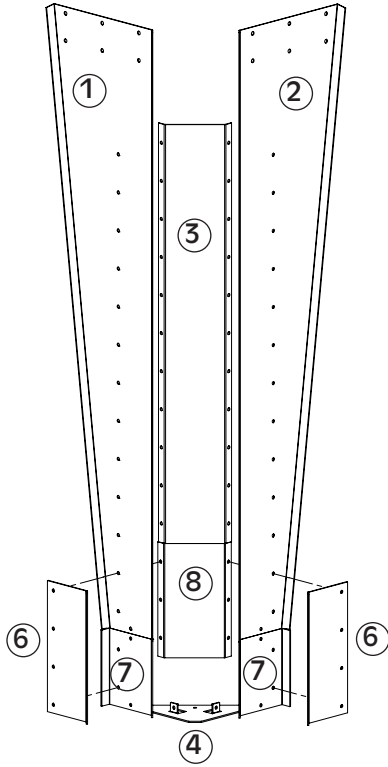
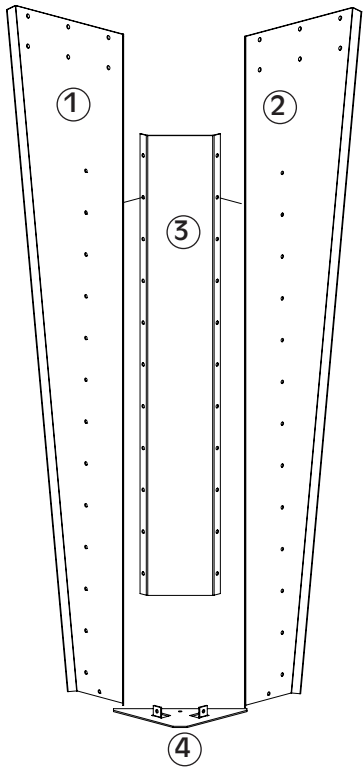
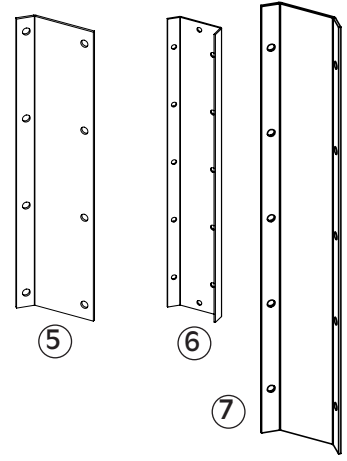
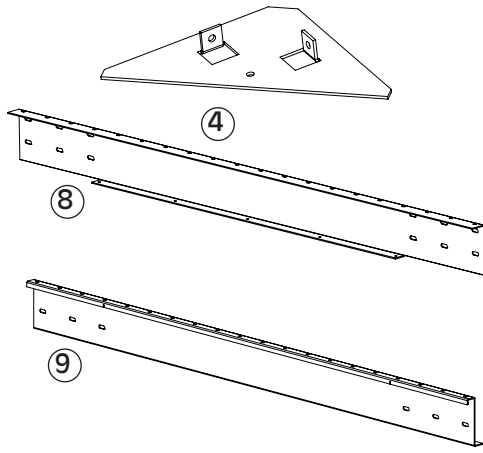
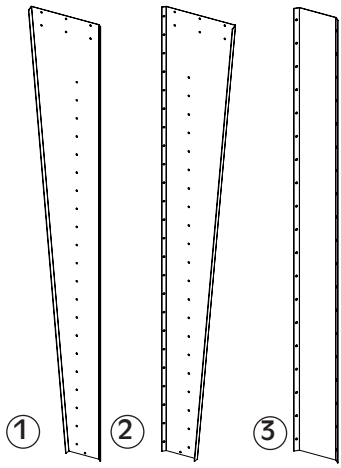

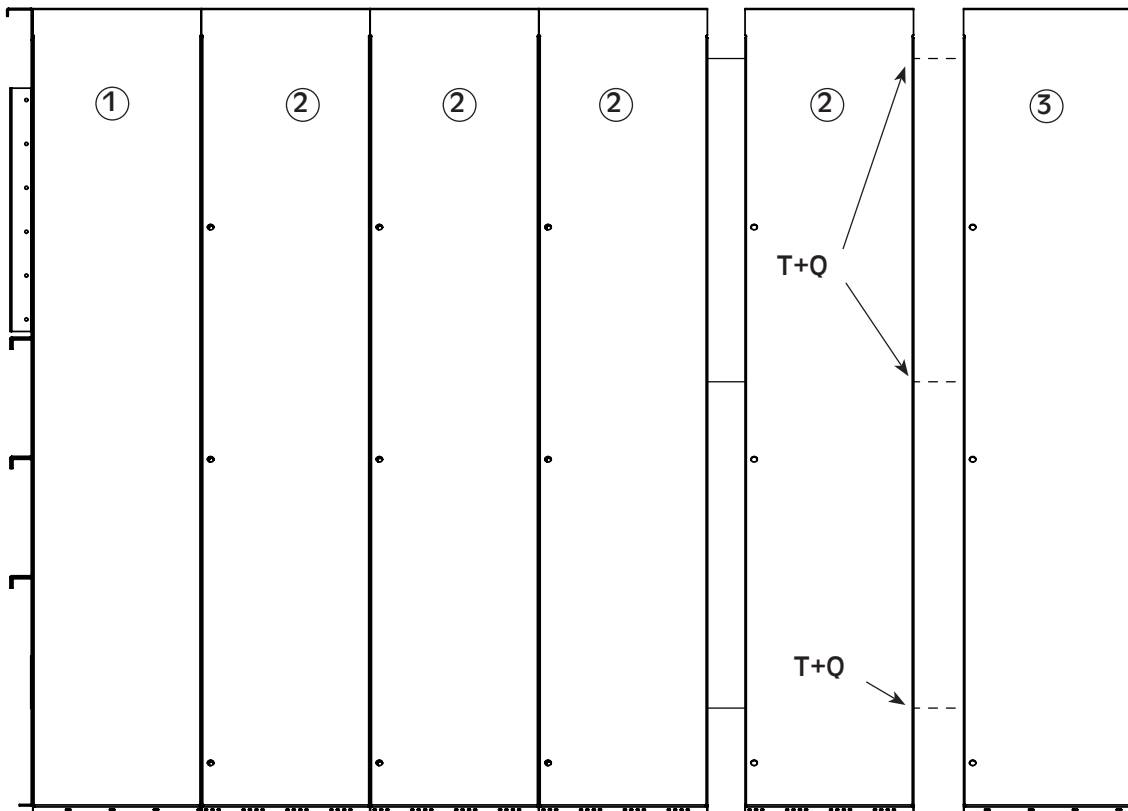
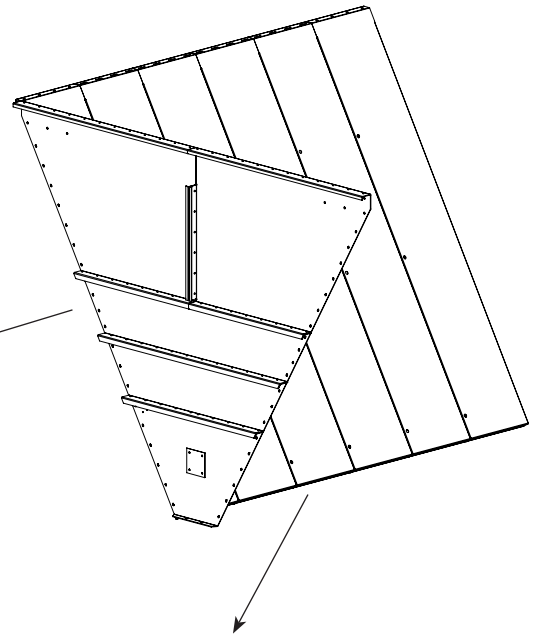
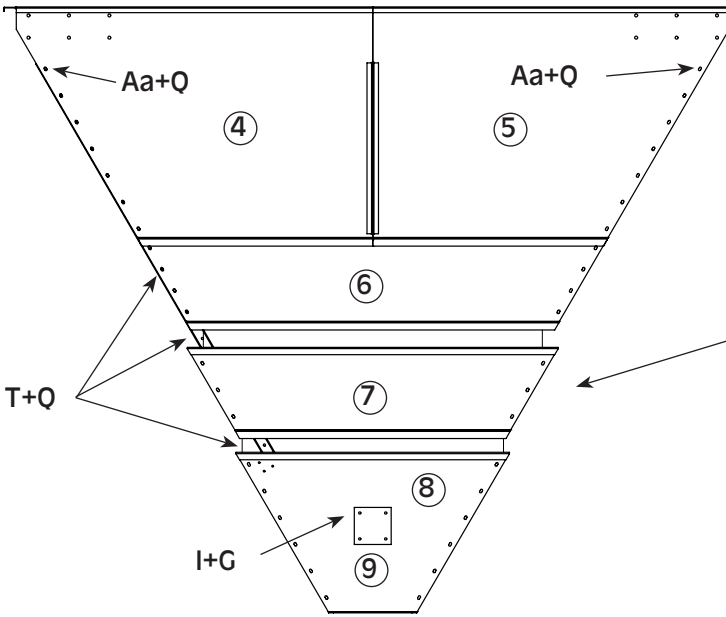
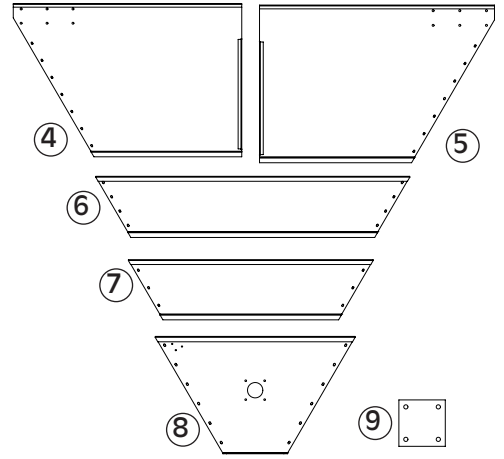
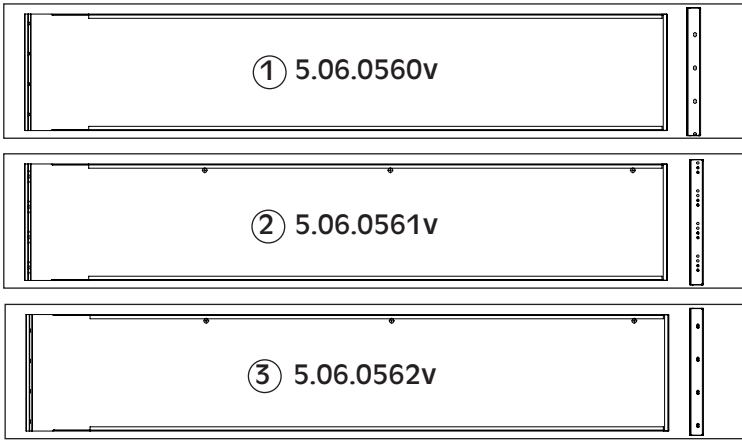

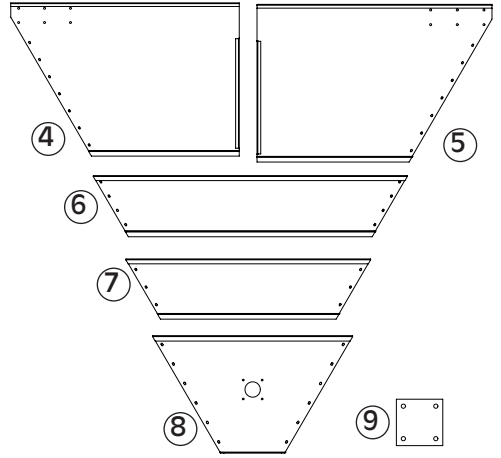
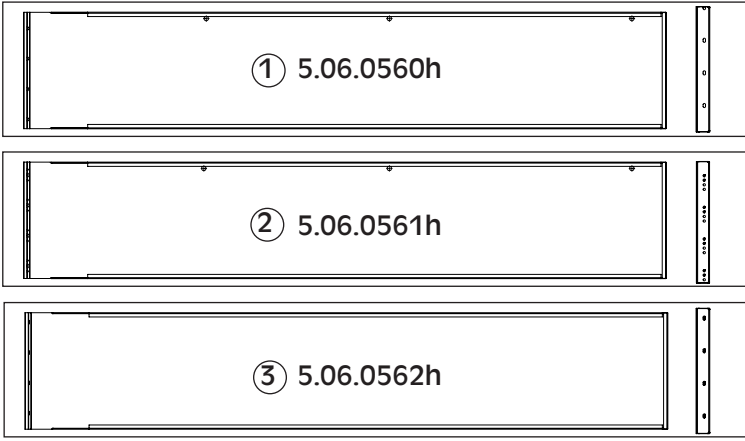

Page -18-

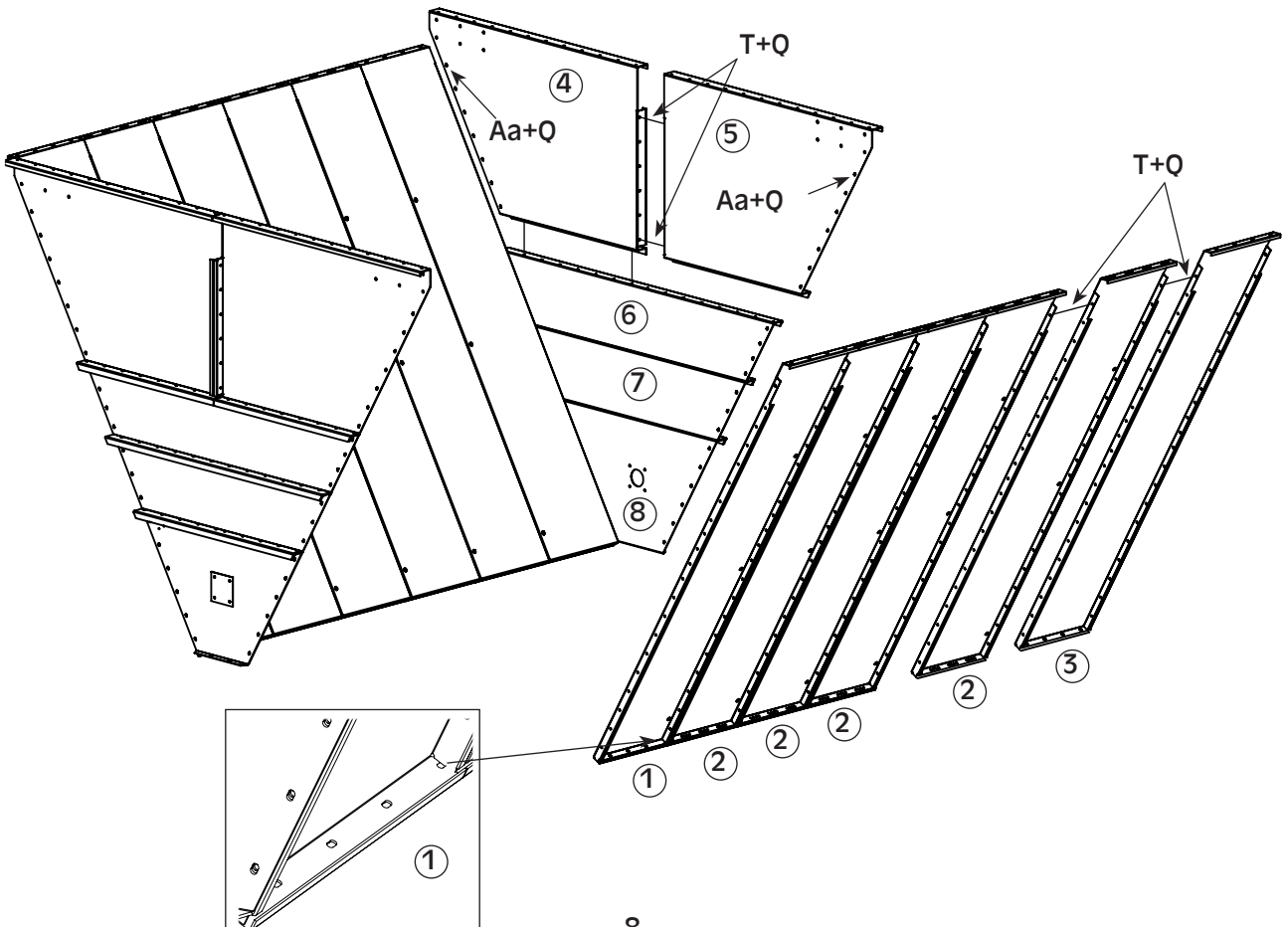
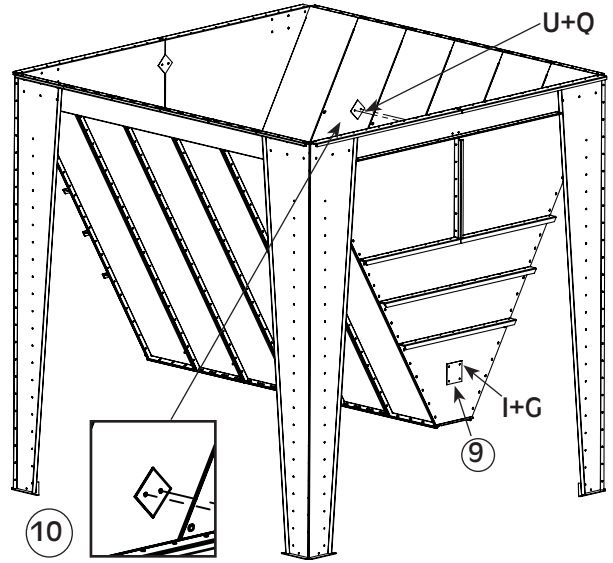
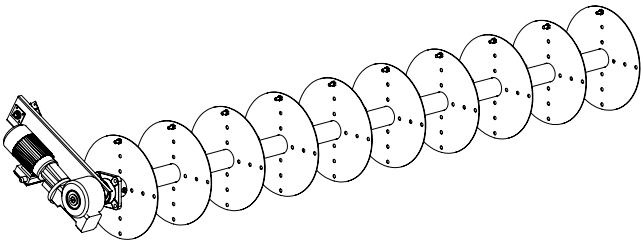



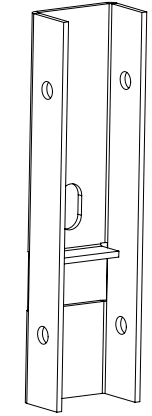
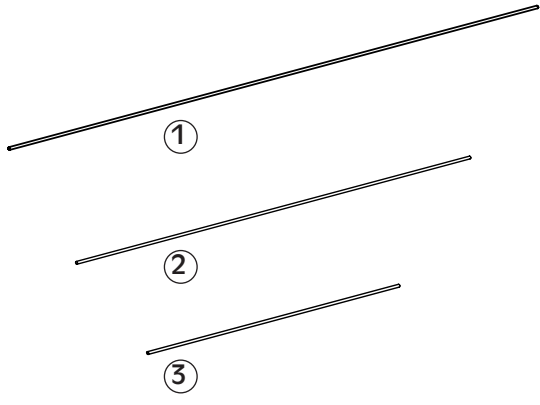

④ 4.04.6013

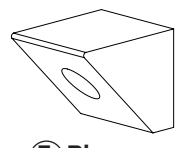

⑤ Bb

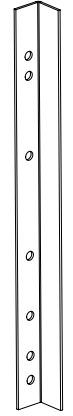

⑥ 4.04.6014

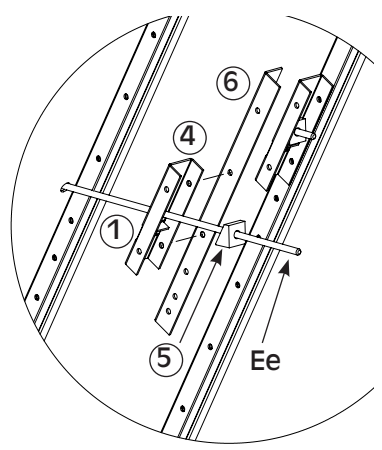
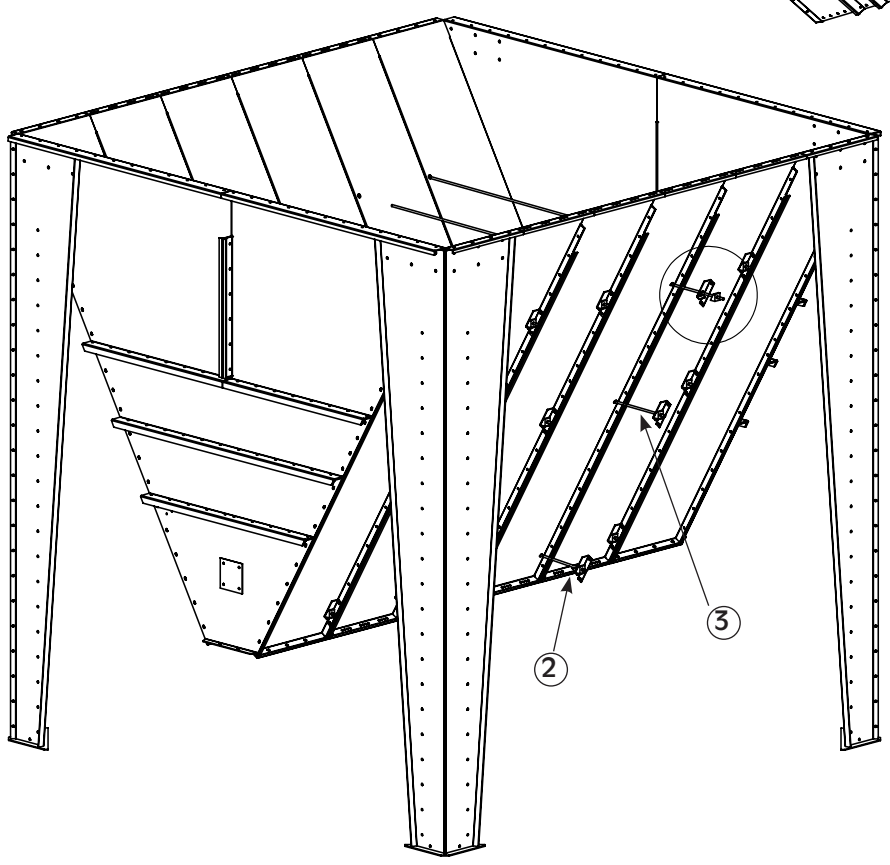
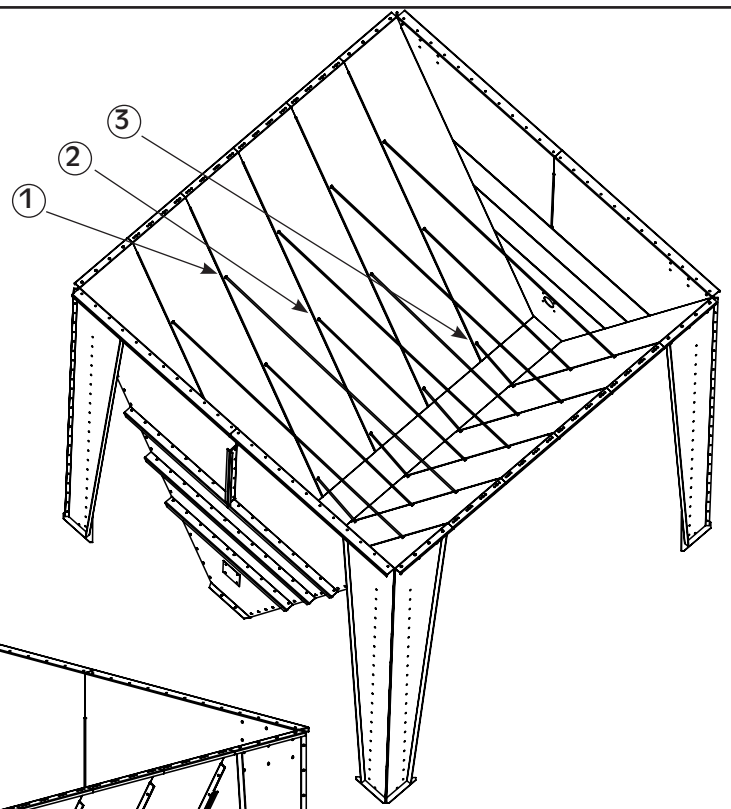

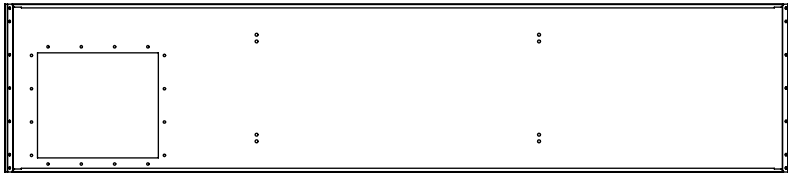

①



②



③ 4.06.0050

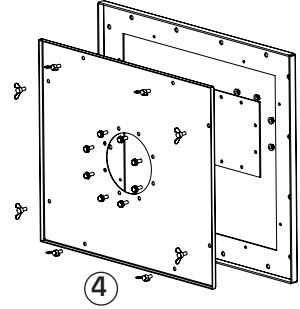

④

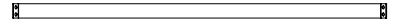

⑤ 4.06.0051

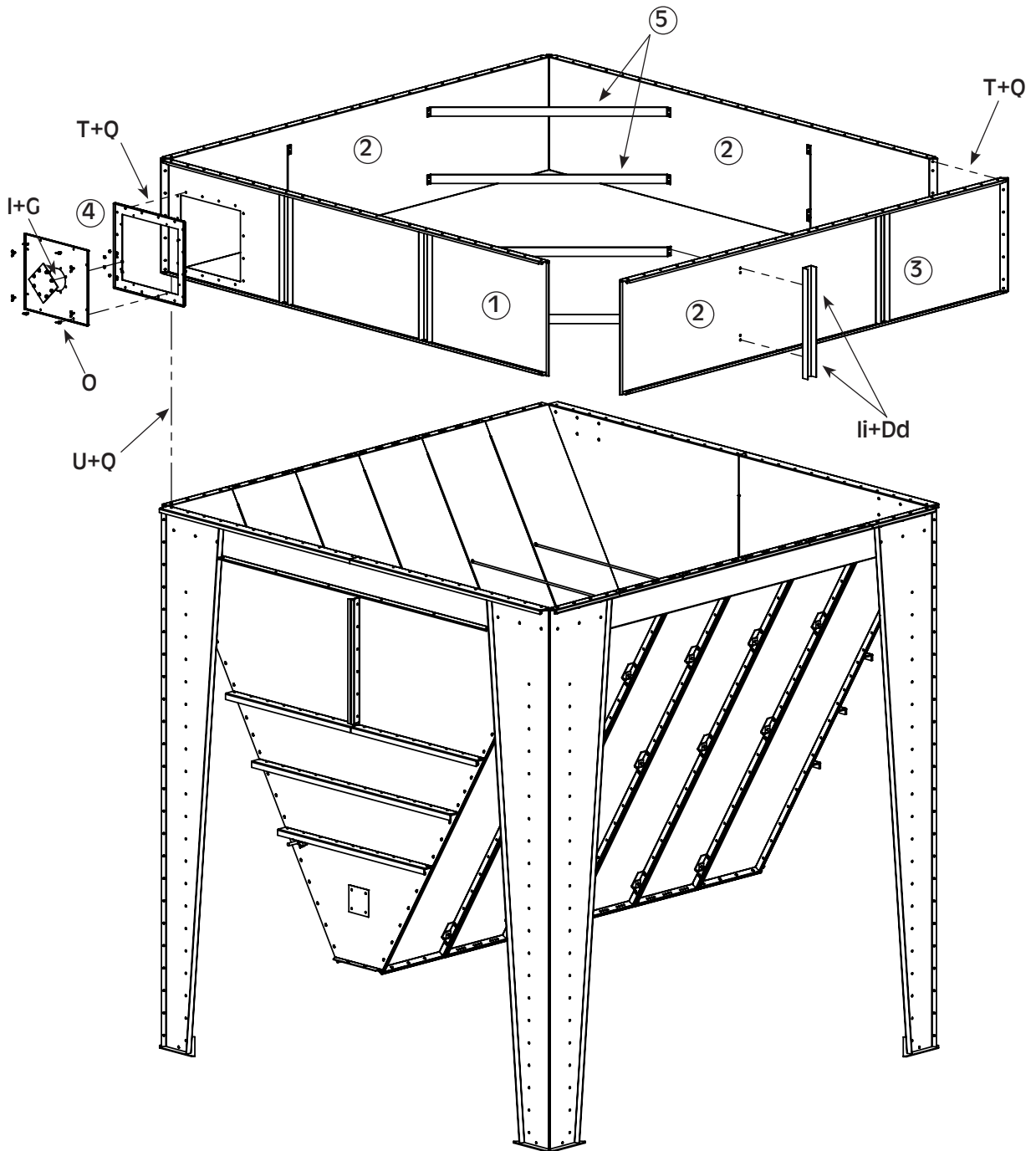

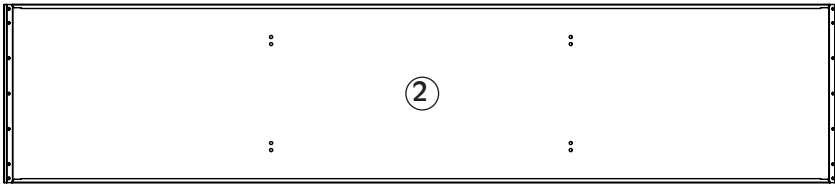
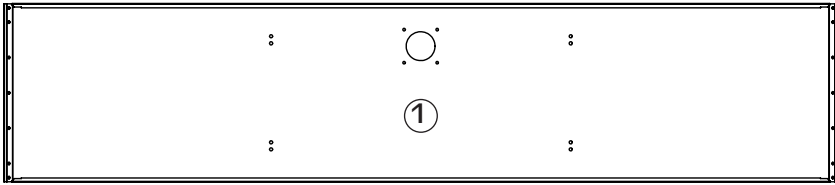

③ 4.06.0050



⑤ 4.06.0051

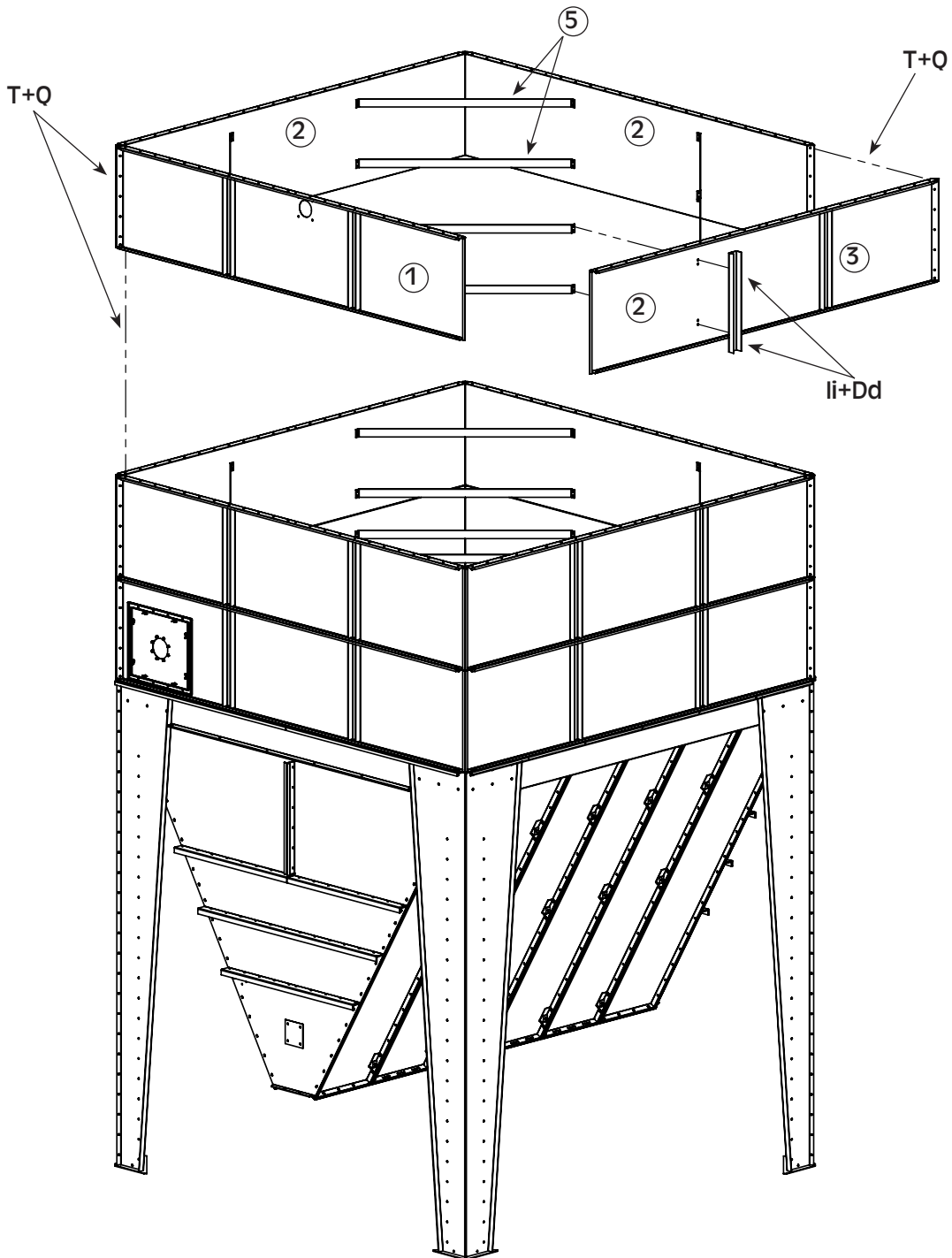

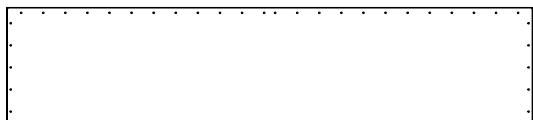

① 4.06.0066

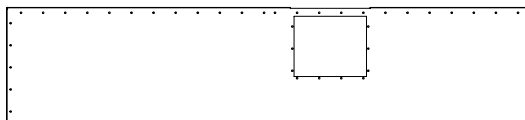

② 4.06.0065

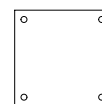

⑤ 4.00.0021



③ 4.06.0062



④ 4.06.0043

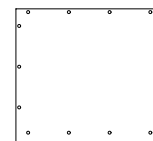

⑥ 4.00.0022

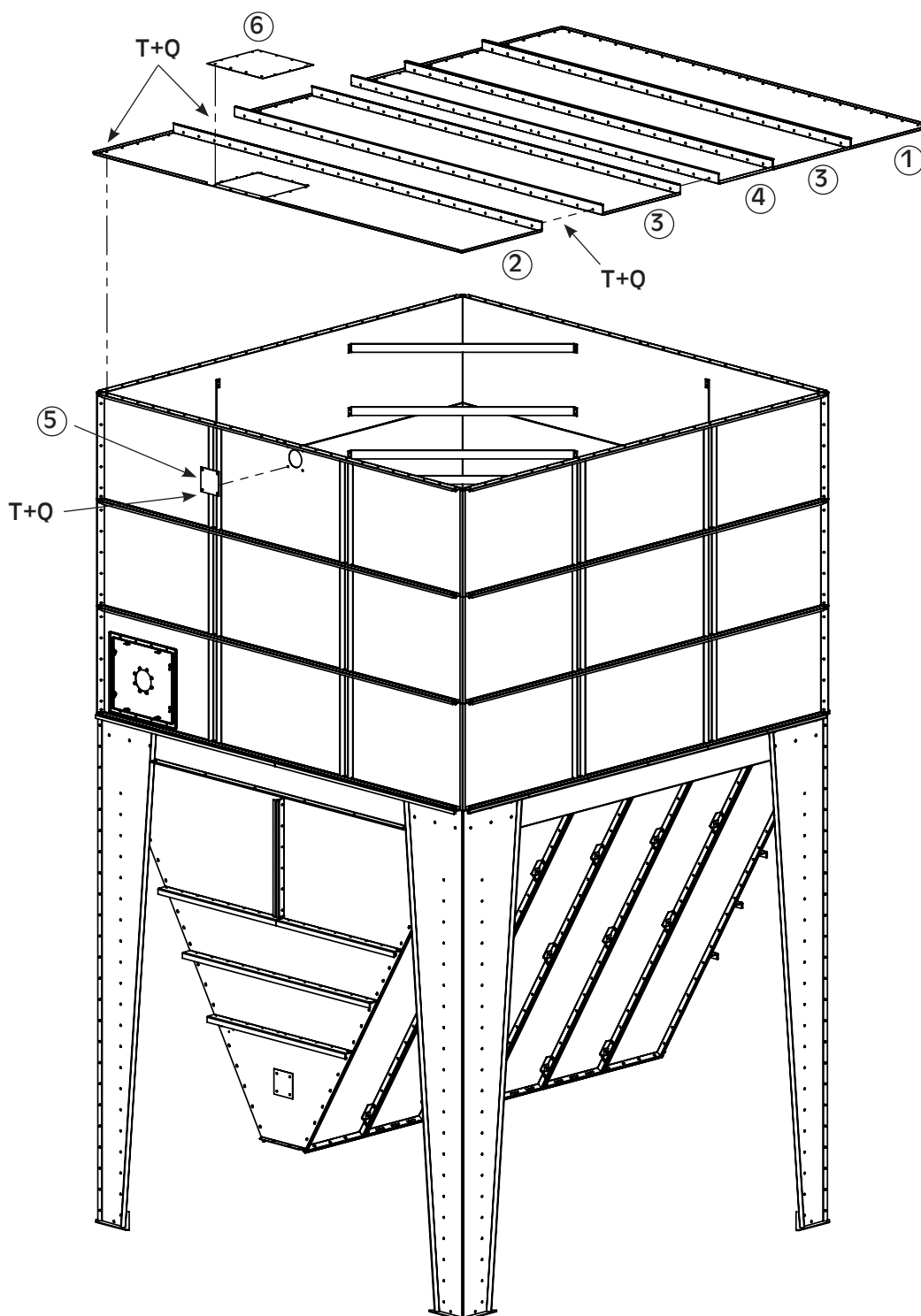

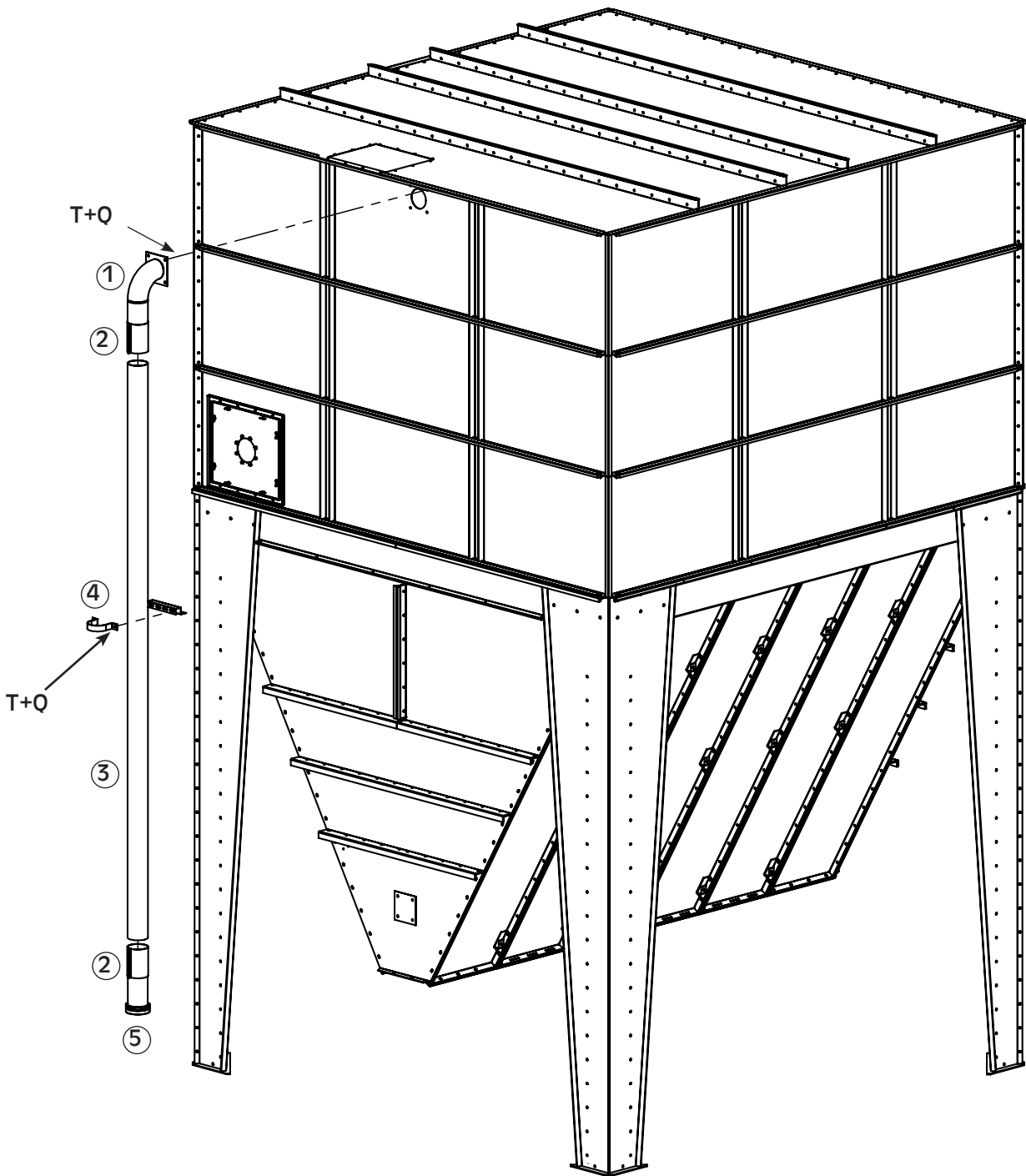
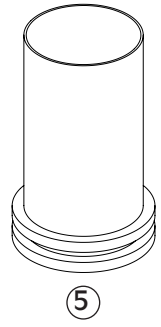
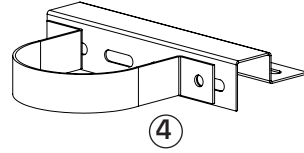
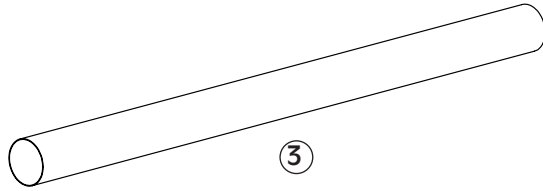
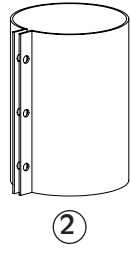
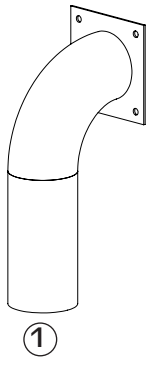

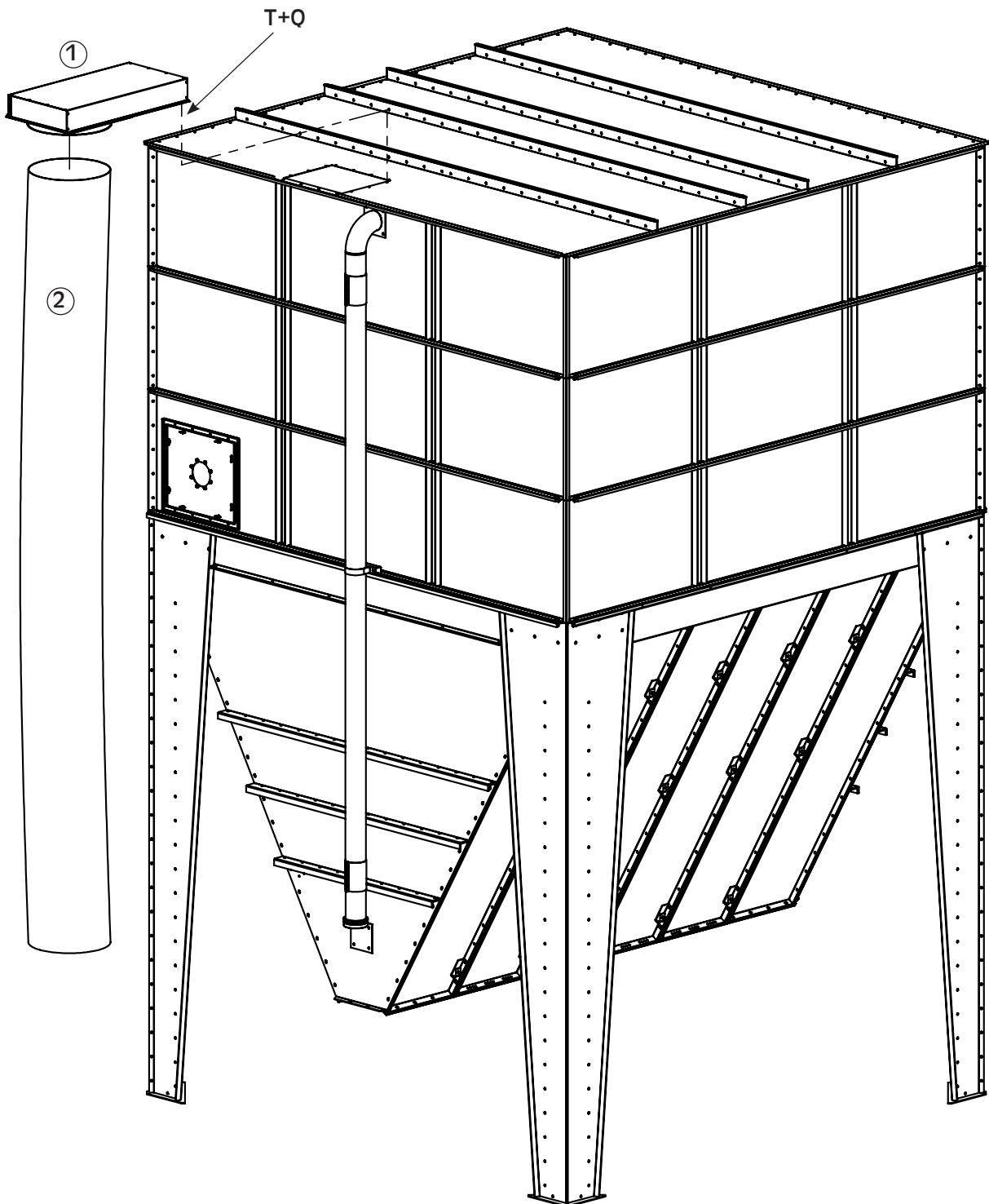
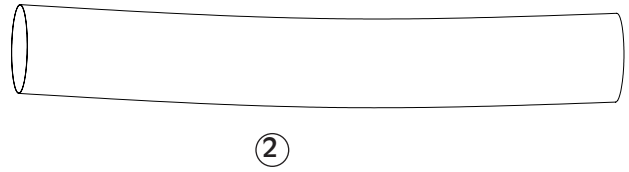
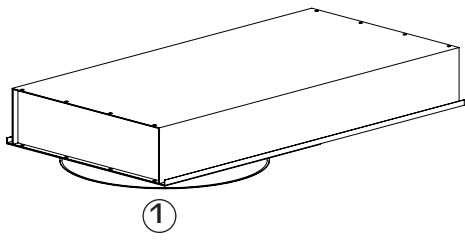

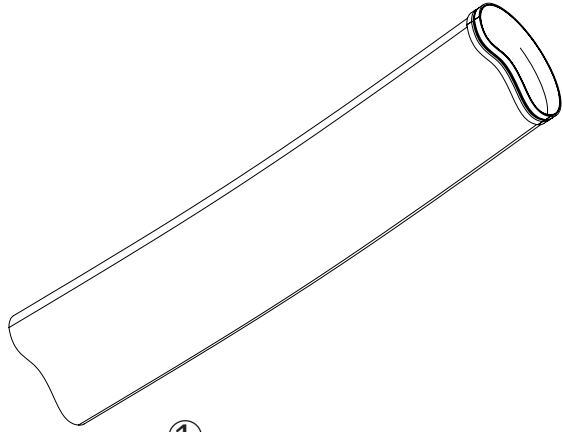

①

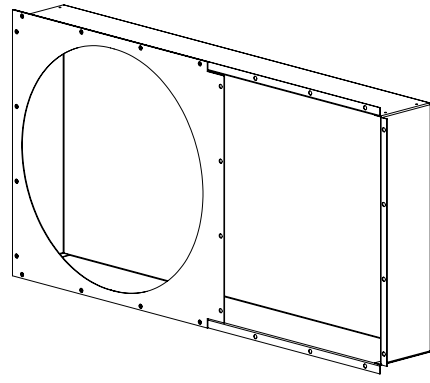

② 4.00.0009

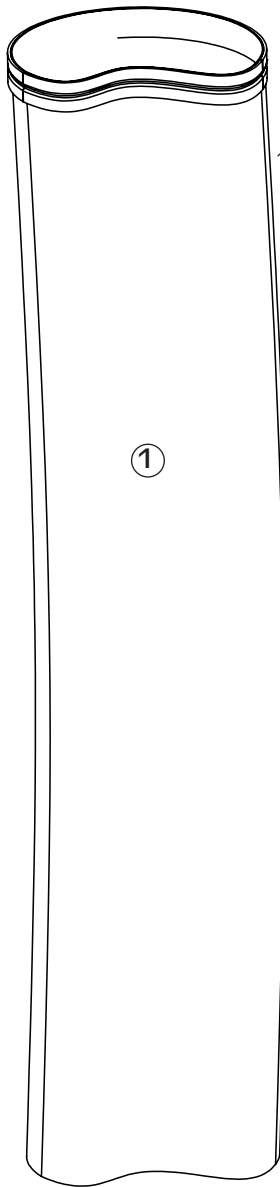

①

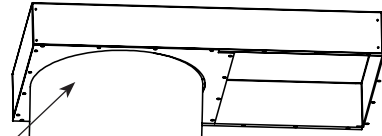

②

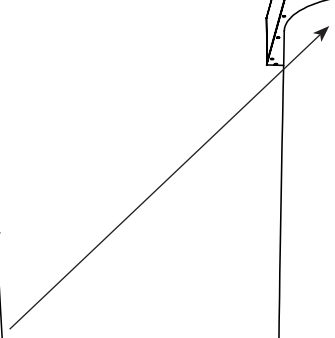

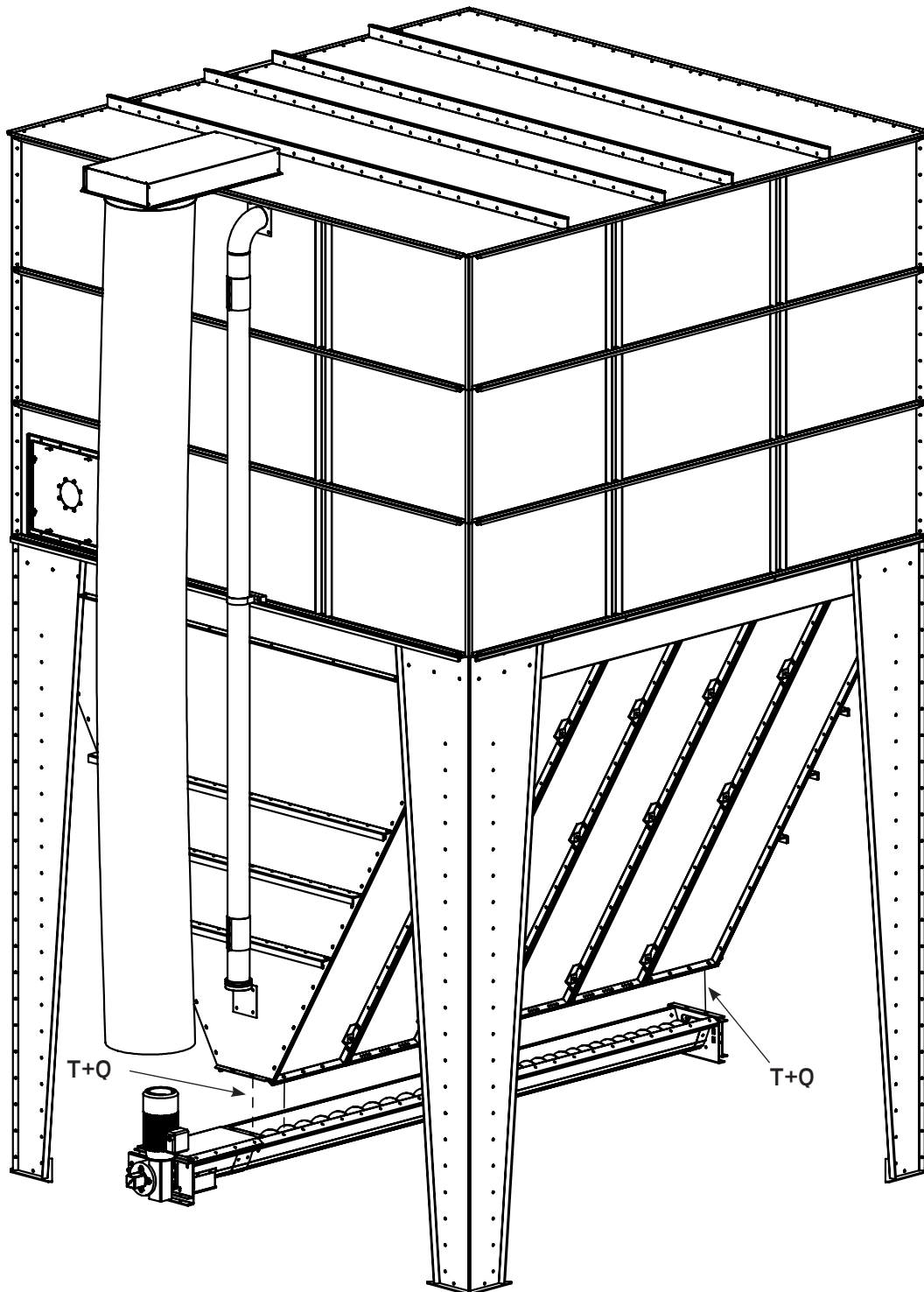
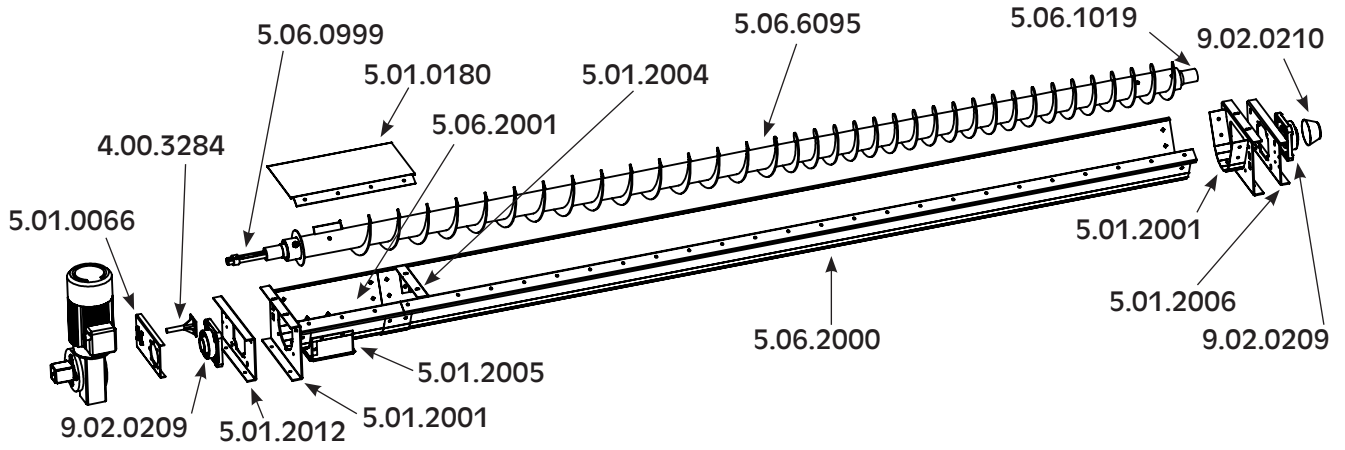



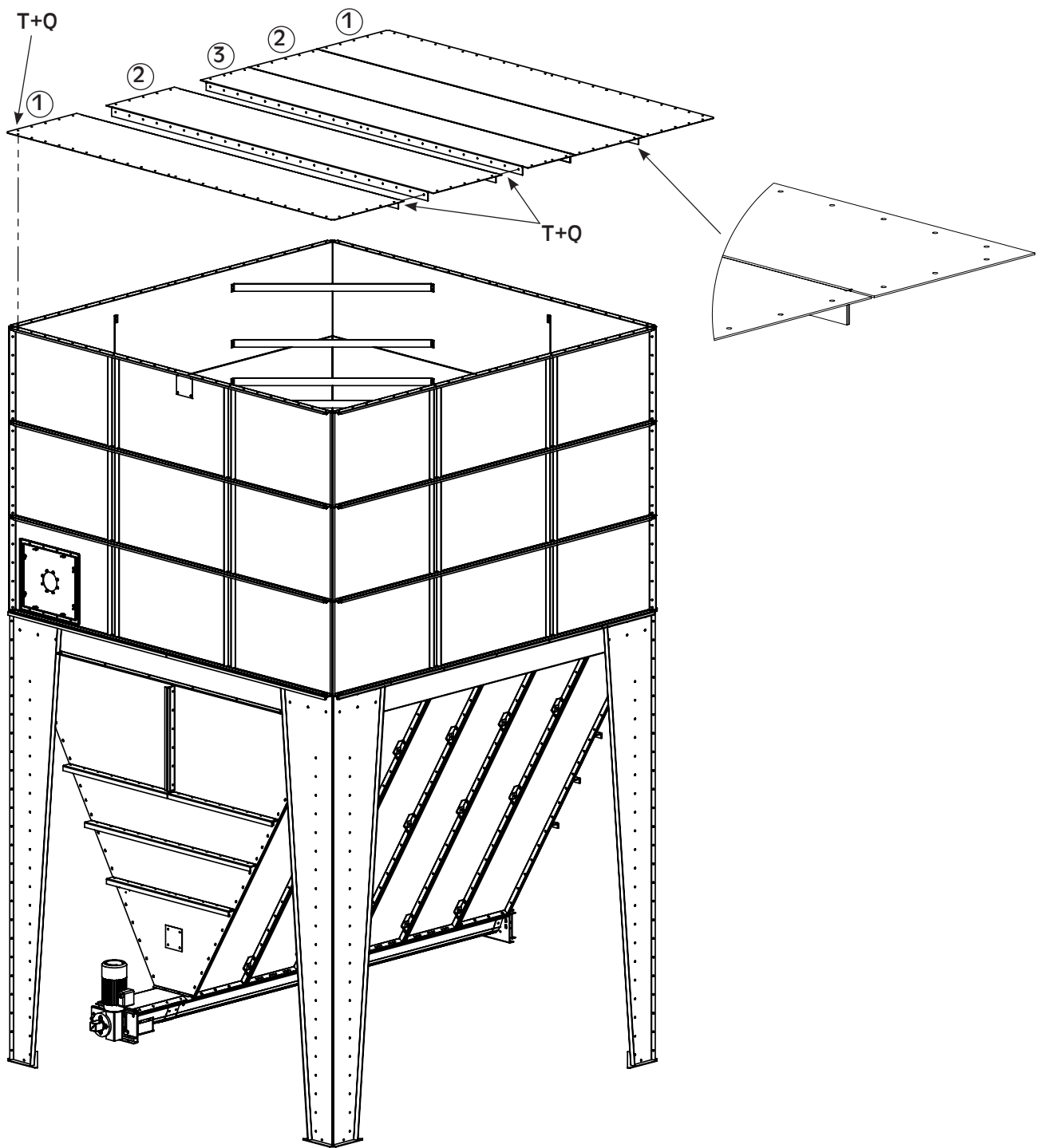
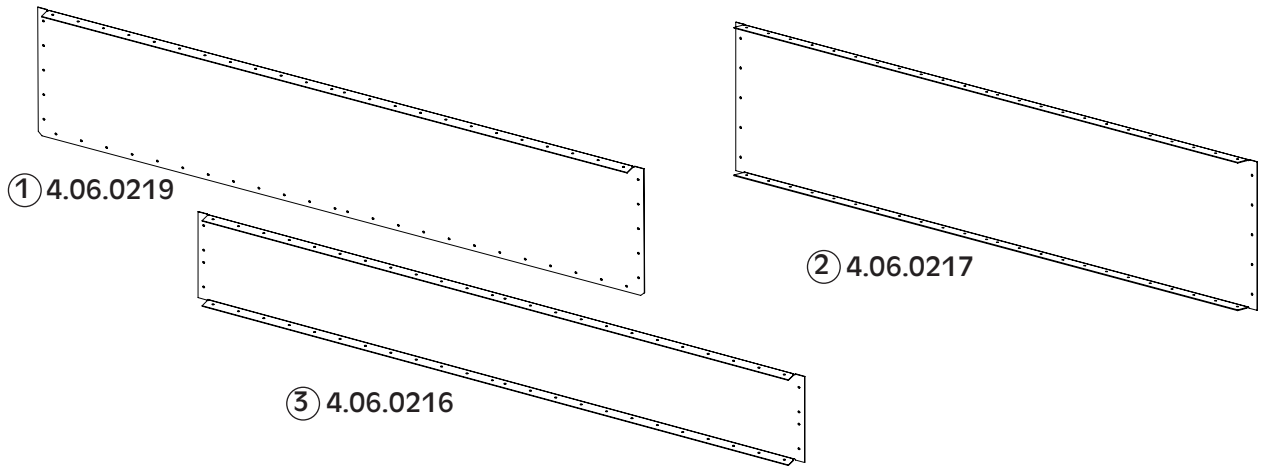

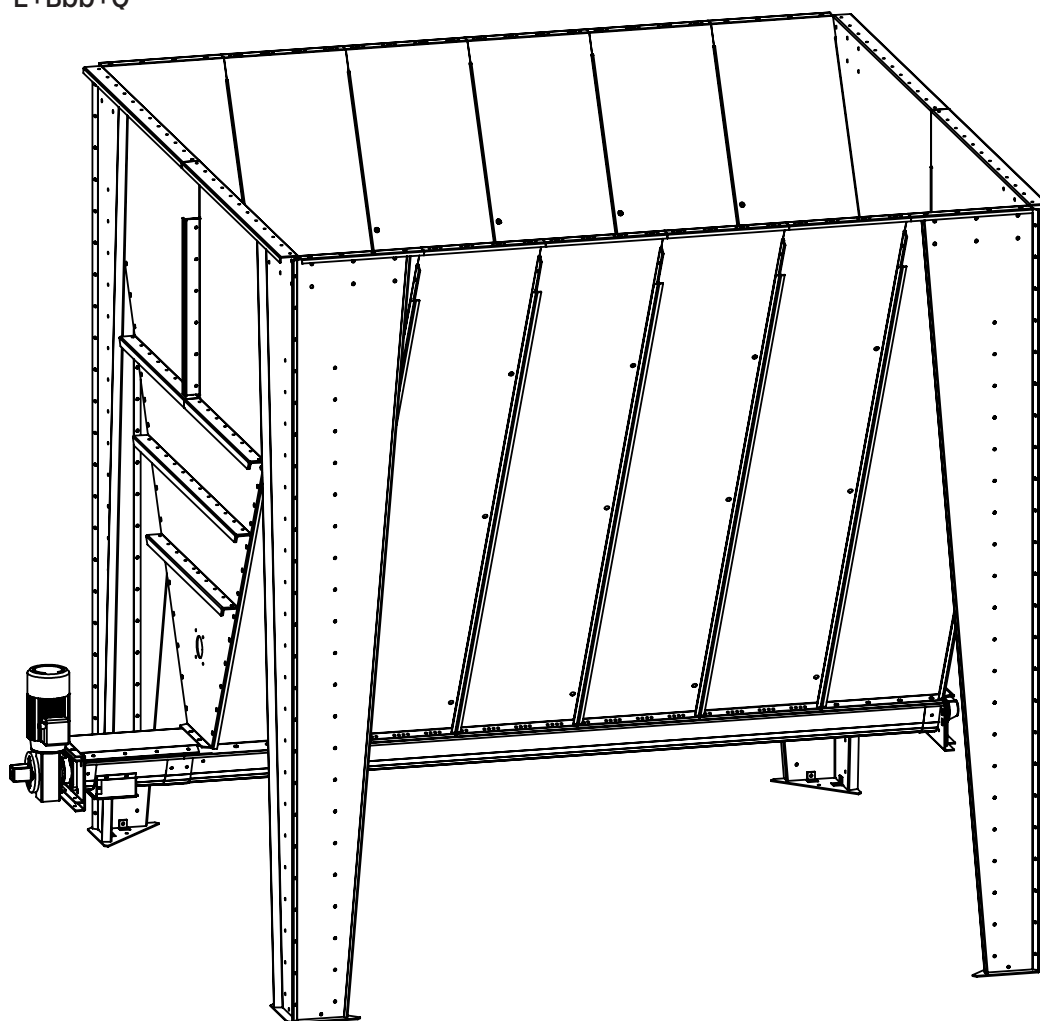
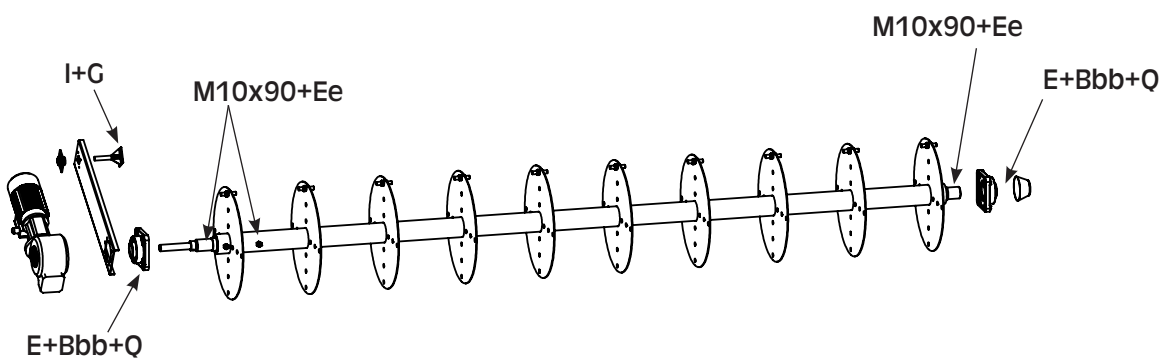
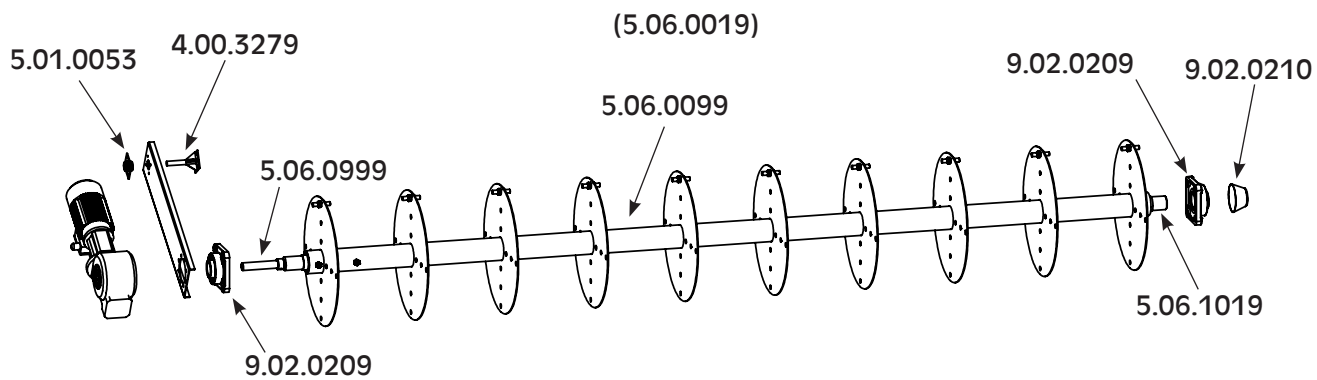

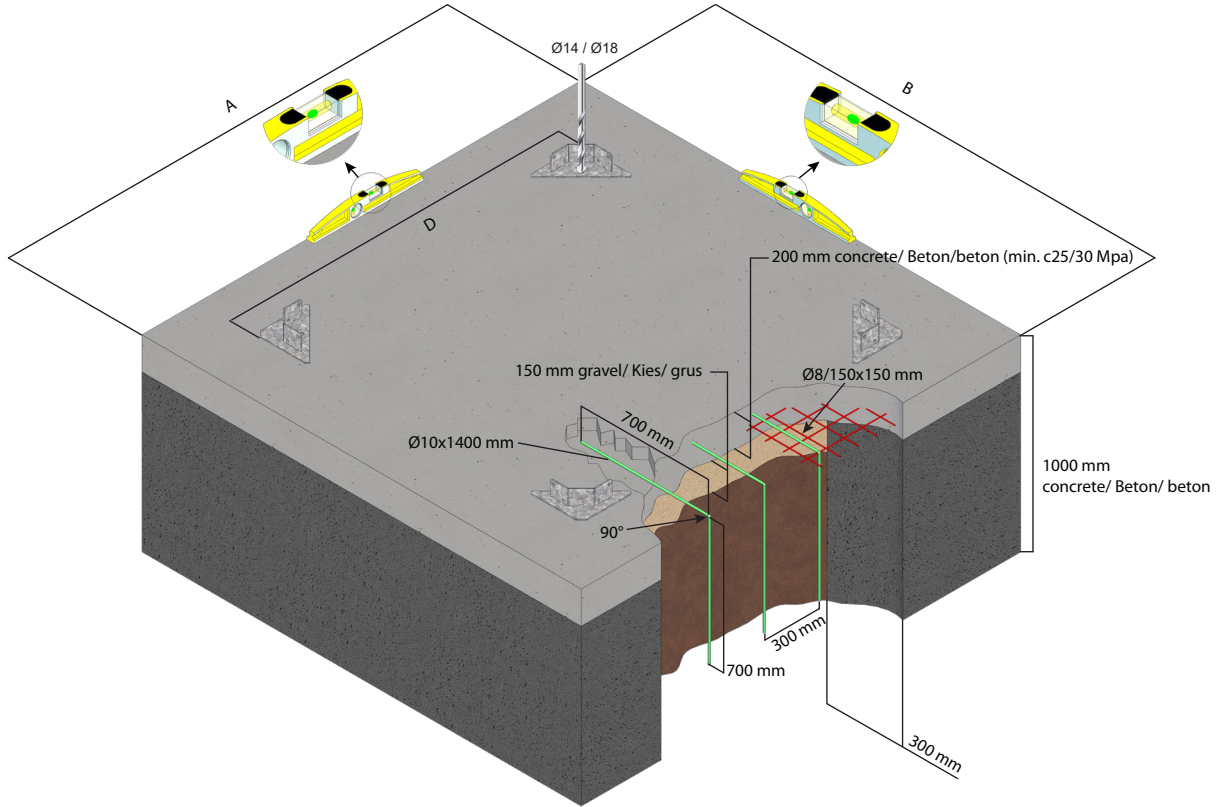

Silo	Mål - Dimensions - Maße [mm]
Type - Type - Typ 150	
A = B	1700
D	1334
Type - Type - Typ 200	
A = B	2200
D	2038
Type - Type - Typ 250	
A = B	2700
D	2547
Type - Type - Typ 300	
A = B	3150
D	2980

